

# R3

## USER MANUAL

RGBW Beam • Wash  
with 4°-34° linear zoom

## TABLE OF CONTENTS

### INTRODUCTION

Features  
Specifications  
Package contents  
Physical dimensions  
External overview

### FUNCTIONS and OPERATION

Power On/Off  
Menu navigation  
Menu function chart

### PHOTOMETRICS

Master/Slave linking

DMX starting address  
DMX channel mode  
Example of DMX addressing

### DMX CHARTS

### MENU FUNCTIONS

DMX cable pin-out and termination illustration

Installation and mounting illustration

## - 1.2 - MAINTENANCE

### MAINTENANCE AND CLEANING THE UNIT

- Make sure the area below the installation place is free from unwanted persons during setup.
- Switch off the unit, unplug the main cable and wait until the unit has cooled down.
- All screws used for installing the device and any of its parts should be tightly fastened and should not be corroded.
- Housings, fixations and installation spots (ceiling, trusses, suspensions) should be totally free from any deformation.
- The main cables must be in impeccable condition and should be replaced immediately even when a small problem is detected.
- It is recommended to clean the front at regular intervals, from impurities caused by dust, smoke, or other particles to ensure that the light is radiated at maximum brightness. For cleaning, disconnect the main plug from the socket. Use a soft, clean cloth moistened with a mild detergent. Then carefully wipe the part dry. For cleaning other housing parts use only a soft, clean cloth. Never use a liquid, it might penetrate the unit and cause damage to it.

### TROUBLESHOOTING

Problems	Possible causes	Checks and remedies
Fixture does not light up	<ul style="list-style-type: none"> <li>• No mains supply</li> <li>• Dimmer fader set to 0</li> <li>• All color faders set to 0</li> <li>• Faulty LED</li> <li>• Faulty LED board</li> </ul>	<ul style="list-style-type: none"> <li>• Check the power supply voltage</li> <li>• Increase the value of the dimmer channels</li> <li>• Increase the value of the color channels</li> <li>• Replace the LED board</li> <li>• Replace the LED board</li> </ul>
General low light intensity	<ul style="list-style-type: none"> <li>• Dirty lens assembly</li> <li>• Misaligned lens assembly</li> </ul>	<ul style="list-style-type: none"> <li>• Clean the fixture regularly</li> <li>• Install lens assembly properly</li> </ul>
Fixture does not power up	<ul style="list-style-type: none"> <li>• No power</li> <li>• Loose or damaged power cord</li> <li>• Faulty internal power supply</li> </ul>	<ul style="list-style-type: none"> <li>• Check for power on power outlet</li> <li>• Check power cord</li> <li>• Replace internal power supply</li> </ul>
Fixture does not respond to DMX	<ul style="list-style-type: none"> <li>• Wrong DMX addressing</li> <li>• Damaged DMX cables</li> <li>• Bouncing signals</li> </ul>	<ul style="list-style-type: none"> <li>• Check control panel and unit addressing</li> <li>• Check DMX cables</li> <li>• Install terminator as suggested</li> </ul>

Contact an authorized service center in case of technical problems or not reported in the table can not be resolved by the procedure given in the table.



**WARNING!** Before carrying out any operations with the unit, carefully read this instruction manual and keep it with care for future reference. It contains important information about the installation, usage and maintenance of the unit.



## SAFETY

### General instruction

- The products referred to in this manual conform to the European Community Directives and are therefore marked with **CE**.
- The unit is supplied with hazardous network voltage (230V~). Leave servicing to skilled personnel only. Never make any modifications on the unit not described in this instruction manual, otherwise you will risk an electric shock.
- Connection must be made to a power supply system fitted with efficient earthing (Class I appliance according to standard EN 60598-1). It is, moreover, recommended to protect the supply lines of the units from indirect contact and/or shorting to earth by using appropriately sized residual current devices.
- The connection to the main network of electric distribution must be carried out by a qualified electrical installer. Check that the main frequency and voltage correspond to those for which the unit is designed as given on the electrical data label.
- This unit is not for home use, only professional applications.
- Never use the fixture under the following conditions:
  - in places subject to vibrations or bumps;
  - in places with a temperature of over 40 °C.
- Make certain that no inflammable liquids, water or metal objects enter the fixture.
- Do not dismantle or modify the fixture.
- All work must always be carried out by qualified technical personnel. Contact the nearest sales point for an inspection or contact the manufacturer directly.
- If the unit is to be put out of operation definitively, take it to a local recycling  plant for a disposal which is not harmful to the environment.

### Warnings and installation precautions

- If this device will be operated in any way different to the one described in this manual, it may suffer damage and the guarantee becomes void. Furthermore, any other operation may lead to dangers like short circuit, burns, electric shock, etc.
- Before starting any maintenance work or cleaning the projector, cut off power from the main supply.
- Always additionally secure the projector with the safety rope. When carrying out any work, always comply scrupulously with all the regulations (particularly regarding safety) currently in force in the country in which the fixture's being used.
- Install the fixture in a well ventilated place.
- Keep any inflammable material at a safe distance from the fixture.
- Shields, lenses or ultraviolet screens shall be changed if they have become damaged to such an extent that their effectiveness is impaired.
- The lamp (LED) shall be changed if it has become damaged or thermally deformed.
- Never look directly at the light beam. Please note that fast changes in lighting, e. g. flashing light, may trigger epileptic seizures in photosensitive persons or persons with epilepsy.
- Do not touch the product's housing when operating because it may be very hot.

## FEATURES

- 4°-34° linear zoom
- Compact, lightweight, fast
- Two pan/tilt speed modes (normal & turbo)
- Onboard user preset library (save/load)
- Built-in color and strobe macros
- RGB Gamma adjustment
- White color temp presets from 2500~8000K
- Flawless 16-bit 540°/270° motorized pan/tilt movement
- Selectable PWM frequency for flicker-free video with any camera
- DMX, RDM control

## SPECIFICATIONS

### PHOTOMETRICS

Light Source:	7 x 40W RGBW LEDs
Linear zoom:	4° - 34°
Output (lux):	18144lx ~ 439lx (min ~ max beam angle) @ 5 meters

### POWER

Mains:	100 - 240 VAC, 50/60 Hz
Consumption:	310W @ 230V
Power connections:	PowerCon In/Out

### KEY FEATURES

Color mixing:	RGBW
Macros:	Colors, Strobe
Strobe:	1 ~ 30Hz + strobe effects
Dimming:	0-100% with 4 dimming curve modes
Pan movement:	540°
Tilt movement:	270°
Pan/Tilt modes:	Normal / Turbo

### CONTROL

Protocol:	DMX, RDM
DMX channels:	16 / 20
Data connections:	XLR In/Out for DMX
Onboard menu:	TFT display with 4-button navigation

### PHYSICAL

Material:	Plastic and aluminium
Finish:	Matte black
IP rating:	IP20
Cooling:	Active (variable speed fan + silent mode)
Dimensions:	249 x 183 x 345 mm
Weight:	6.6 KG
Mounting:	Omega Bracket (included)

**Package contents**

- R3
- Power cable
- User manual
- Mounting bracket
- Warranty card

**DIMENSIONS**

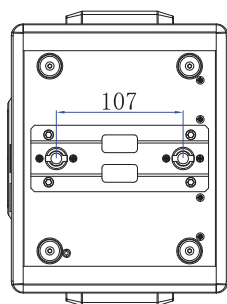
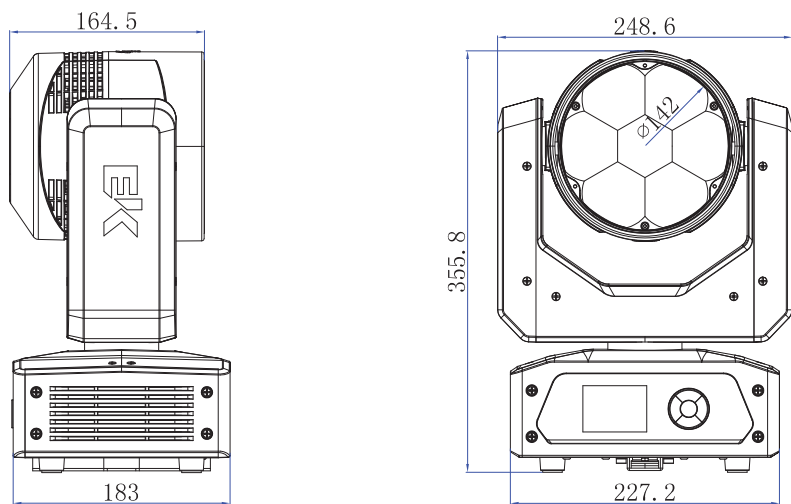

**DMX CABLE PIN-OUTS and TERMINATION**

Depending on the length of the DMX cable run, or other factors, it may be advisable to install a terminator at the last fixture in the run.

The illustration below shows the correct placement of a 120Ω 0.25W resistor in a terminator, as well as the standard DMX signal pin-outs.

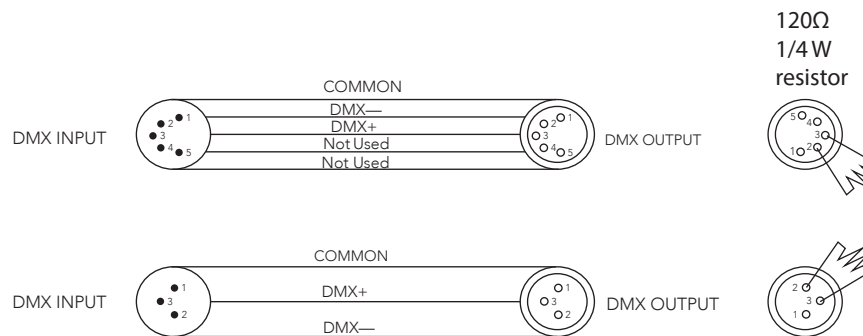

**INSTALLATION**

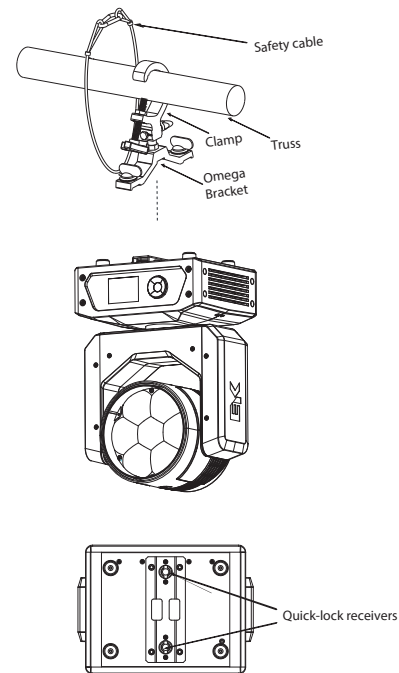

## TEST MENU

Run live tests of these functions:

- Pan / Tilt
- Color
- Zoom
- All

## ADVANCED MENU

Enter access code (default: 1234) to calibrate physical offsets of the pan, tilt, zoom, and to adjust individual red, green, blue and white LED output to achieve proper white balance.

## OVERVIEW

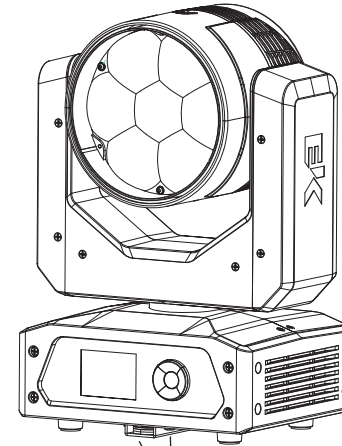

Omega bracket mounting plate

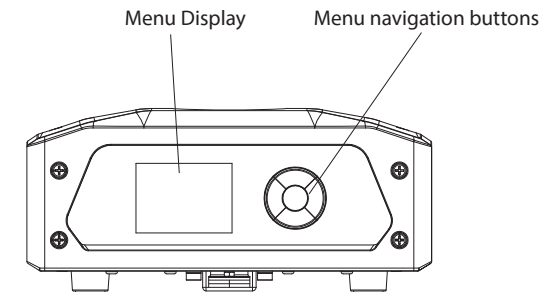

Menu Display

Menu navigation buttons

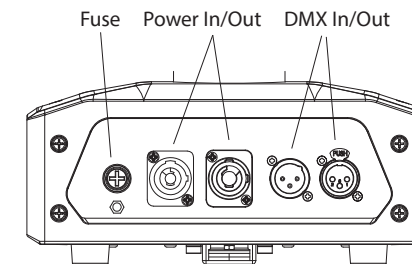

Fuse

Power In/Out

DMX In/Out

## FUNCTIONS and OPERATION

### POWER ON/OFF

The fixture is powered on by connecting the included power cable to mains power (100 - 240 VAC, 50/60 Hz). Upon receiving power, the fixture will cycle through a motor reset program. To power off, disconnect the power cable or turn off power remotely using a switch.

### MENU NAVIGATION

The control panel features five-button navigation of the onboard menu.

If the panel is password-protected, go to the Advanced menu, in the Menu locking submenu, enter the Unlock code using the navigation buttons:

1234

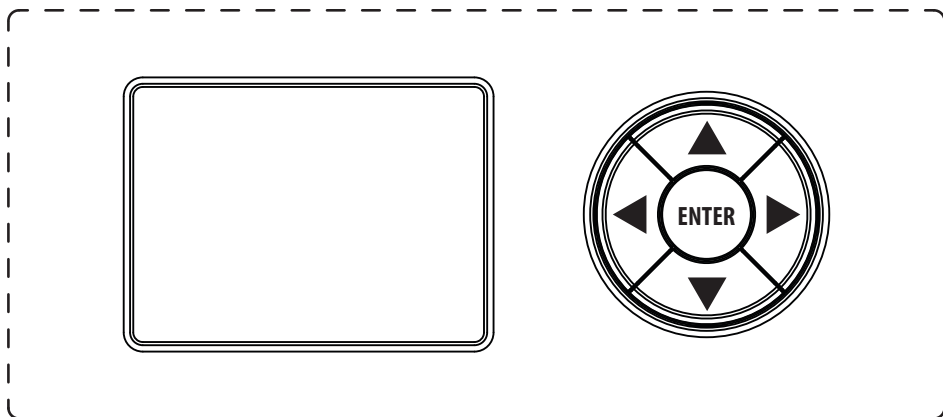

UP	DOWN	LEFT	RIGHT	ENTER
Increase the displayed value, or scroll thru previous menu items	Decrease the displayed value, or scroll thru next menu items	Return to higher menu levels	Advance displayed unit values by 10x and 100x	Confirm displayed values, or activate displayed functions, or enter submenus

## SET UP MENU

DMX ADDRESS : Set starting address value

DMX CHANNEL : Select 16- or 20-channel mode

### OPTION MENU

PAN / TILT : Set values for:

- Invert Pan
- Invert Tilt
- Swap Pan-Tilt
- Encoder Pan-Tilt
- Pan/Tilt Homing Mode
- Pan Home Default Position
- Tilt Home Default Position
- Pan/Tilt Enable

DISPLAY : Set display behavior (on/off)

FAN MODE : Select Auto or Silent fan mode

SPECIAL FUNCTIONS :

- Pan/Tilt speed: Select Normal or Fast
- Dimmer curve: Select one of four dimmer curves
- RGB Gamma: Select desired gamma setting
- PWM Frequency: Select frequency to avoid camera flicker

SETTING : Load parameter presets for :

- Factory defaults
- User presets 1
- User presets 2
- User presets 3

### INFORMATION MENU

Displays stored data and values for:

- System errors
- Fixture operating hours
- LED hours
- System firmware versions
- DMX monitor
- Fans monitor
- Unique RDM identifier

### MANUAL CONTROL

RESET : Force fixture to reset

CHANNEL : Set output for each DMX channel

7	11	Strobe	000-003	Closed
			004-103	Slow to Fast Strobe(1-25Hz)
			104-107	Open
			108-207	Slow to Fast Pulsation
			208-212	Open
			213-225	Random Slow Strobe
			226-238	Random Medium Strobe
			239-251	Random Fast Strobe
252-255	Open			
8	12	Dimmer	000-255	
9	13	Dimmer Fine	000-255	
10	14	Pan	000-255	
11	15	Pan Fine	000-255	
12	16	Tilt	000-255	
13	17	Tilt Fine	000-255	
14	18	Zoom	000-255	Zoom linearly moves from narrow to wide beam
15	19	Function	000-011	None
			012-024	Fast P&T speed (Default)
			025-037	Normal P&T speed
			038-042	Dimmer curve 1 (Default)
			043-047	Dimmer curve 2
			048-052	Dimmer curve 3
			053-057	Dimmer curve 4
			058-062	Raw color channels gamma 1
			063-067	Raw color channels gamma 1.5
			068-072	Raw color channels gamma 2.2 (Default)
			073-077	Color Calibration Off (Default)
			078-082	Color Calibration Adjust
			083-087	Color Calibration Calibration (Only Base Mode)
			088-167	FREE
			168-188	PWM frequency=600Hz
			189-199	PWM frequency=1200Hz (Default)
			200-210	PWM frequency=2000Hz
			211-221	PWM frequency=4000Hz
			222-232	PWM frequency=6000Hz
			233-243	PWM frequency=25000Hz
244-255	Default function recall			
16	20	Reset	000-025	No Function
			026-076	Zoom Reset (Hold 5S)
			077-127	Pan / Tilt Reset (Hold 5S)
			128-255	Complete Reset (Hold 5S)

	Main Menu	Submenu	Submenu	Submenu	Defaults
1	SETUP	DMX Address	1-512		Default: 1
		DMX Channel	16CH 20CH		Default:Basic 20CH
2	OPTION	Pan / Tilt	Invert Pan	Off	Default: Off
				On	
			Invert Tilt	Off	Default: Off
				On	
			Swap Pan-Tilt	Off	Default: Off
				On	
			Encoder Pan-Tilt	Off	Default: On
				On	
			P/T Homing Mode	Standard	Default: Standard
				Sequenced	
		Pan Home Def Pos	0 degree	Default: 270 degree	
			90 degrees		
			180 degrees		
			270 degrees		
		Tilt Home Def Pos	0%	Default: 50%	
			12.50%		
			25%		
			50%		
			75%		
			87.50%		
P/T Enable	On	Default: On			
	Off				
Display	Off	Default: Off			
	On				
Warning Cue	Off	Default: Off			
	On				
Fan Mode	Auto	Default: Auto			
	SLN				
Special Functions	Pan / Tilt speed	Normal	Default: Fast		
		Fast			
	Dimmer Curve	Dimmer Curve 1	Default: Dimmer Curve 1		
		Dimmer Curve 2			
		Dimmer Curve 3			
		Dimmer Curve 4			
	RGB Gamma	Gamma 1.0	Default: Gamma 2.0		
		Gamma 1.5			
Gamma 2.0					

**MENU FUNCTION CHART**

Main Menu	Submenu	Submenu	Submenu	Defaults			
2	OPTION	Special Functions	PWM Frequency	600Hz	Default:2000Hz		
				1200Hz			
				2000Hz			
				4000Hz			
				6000Hz			
					25000Hz		
	3	INFORMATION	Setting	Default Preset	Reset To Default	Are you sure ?	
					Go Back	Yes / No	
				User Preset 1	Load preset 1	Are you sure ?	
					Save to preset 1	Yes / No	
User Preset 2				Load preset 2	Are you sure ?		
				Save to preset 2	Yes / No		
User Preset 3				Load preset 3	Are you sure ?		
				Save to preset 3	Yes / No		
				System Errors			
Fixture Hours				Total Hours			
				Partial Hours	Reset		
					Go Back		
Led Hours	Total Hours						
	Partial Hours	Reset					
		Go Back					
System Version	DISP:V1.0						
	CTR1-XY:V1.0						
	CTR2-MOTOR:V1.0						
	CTR3-MOTOR:V1.0						
DMX Monitor							
Fans Monitor	Base Fan 100%						
	Led Fan 100%						
UID	030F050*****						

6	10	Macro color	110-111	Spring Yellow
			112	Light Amber
			113	Stra
			114	Deep amber
			115-116	Orange
			117	Light Rose
			118	English Rose
			119	Light Salmon
			120	Middle Rose
			121-122	Dark Pink
			123-124	Magenta
			125	Peacock Blue
			126	Med Blu Green
			127	Steel Blue
			128	Light Blue
			129-130	Dark Blue
			131-133	Leaf Green
			134-135	Dark Green
			136-137	Mauve
			138-141	Bright Pink
			142-144	Medium Blue
			145	Deep Golden Amber
			146	Pale Lavender
			147-148	Special Lavender
			149-150	Primary Green
			151-156	Bright Blue
			157-161	Apricot
			162-167	Pale Gold
			168-171	Deep Orange
			172-173	Bastard Amber
174	Flame Red			
175-178	Daylight Blue			
179	Lilac Tint			
180-183	Deep Lavender			
184-190	Dark Steel Blue			
191-206	Congo Blue			
207	Alice Blue			
208	Dirty White			
209-255	White			



16CH	20CH			
1	1	Red	000-255	
-	2	Red Fine	000-255	
2	3	Green	000-255	
-	4	Green Fine	000-255	
3	5	Blue	000-255	
-	6	Blue Fine	000-255	
4	7	White	000-255	
-	8	White Fine	000-255	
5	9	CTO	000-009	OFF
			010-053	8000K~7000K
			054-098	7000K~6000K
			099-116	6000K~5600K
			117-143	5600K~5000K
			144-187	5000K~4000K
			188-223	4000K~3200K
			224-254	3200K~2500K
			255	2500K
6	10	Macro color	000-009	Macro Color OFF
			10	Red
			11	Green
			12	Blue
			13	Cyan
			14	Yellow
			15	Magenta
			16	White 7000K
			17	White 3700K
			18	White 5000K
			19	Black
			020-022	Medium Yellow
			023-026	Scraw Tint
			027-028	Surprise Peach
			29	Fire
			30	Medium Amber
			31	Gold Amber
			032-034	Dark Amber
			035-044	Sunrise Red
			45	Light Pink
			046-048	Medium Pink
			049-061	Pink Carnation
			062-067	Light Lavender
			068-077	Lavender
			078-088	Sky Blue
			089-099	Just Blue
			100-109	Dark Yellow Green

MENU FUNCTION CHART

	Main Menu	Submenu	Submenu	Submenu	Defaults
4	MANUAL CONTROL	Reset	No		
			Yes		
5	TEST	Pan/Tilt			
			Colour		
			Zoom		
			All		
6	ADVANCED	Calibration	Pan Offset	000-255	
			Tilt Offset	000-255	
			Zoom Offset	000-255	
			Red	125-255	
			Green	125-255	
			Blue	125-255	
		Menu Locking	Unlock Code		Default: 1234
			XXXX		

### PHOTOMETRICS (4° RGBW Beam)

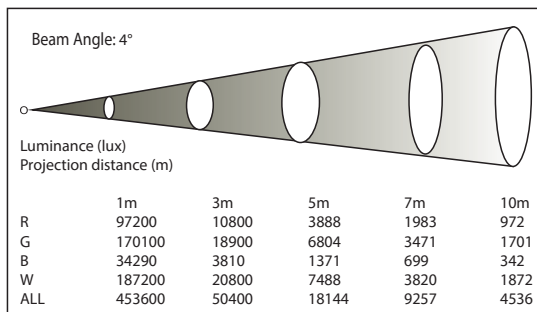

### PHOTOMETRICS (34° RGBW Wash)

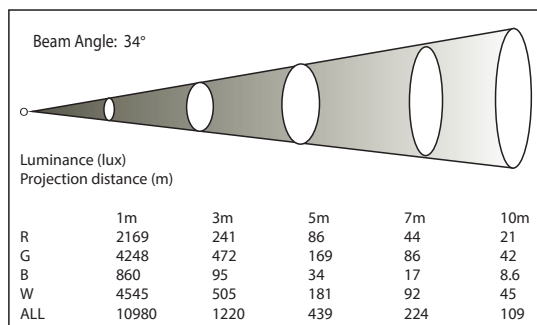

### PHOTOMETRICS (19° White Spot)

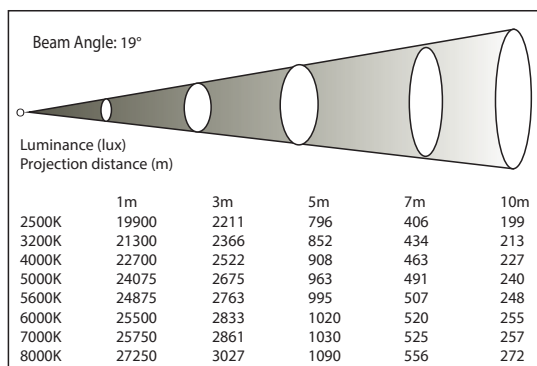

White color temp presets:

	CRI	R9	TM-30-15rg/rf	TLCI
• 2500K :	94.3	97.1	113/83	66.3
• 3200K :	95.4	94.8	106/91	84.4
• 4000K :	94	93.2	106/91	84.6
• 5000K :	92.7	97.7	106/91	83.8
• 5600K :	91.4	90.3	106/90	85
• 6000K :	90.8	97.3	107/89	85.6
• 7000K :	90.1	98	107/88	87.8

### MASTER / SLAVE LINKING

In a connected series of the same fixture, when not using an external controller, a master unit can be assigned to control slave units in the series.

- Set the first fixture in the series to MASTER in the onboard menu
- Set subsequent fixtures to SLAVE
- Connect the DMX OUT of the master unit to the DMX IN of the first slave unit
- Daisy-chain subsequent slave units from DMX OUT to DMX IN

### DMX STARTING ADDRESS

To set the starting address of each fixture:

- Press the ENTER button and use the UP/DOWN buttons to scroll the menu
- Select the CONNECT menu and press ENTER
- Use the UP/DOWN buttons to scroll to the ADDRESS menu
- Press ENTER and use the UP/DOWN buttons to select the DMX address
- Press ENTER to confirm the chosen DMX address
- Press the MENU button to save changes and exit

### EXAMPLE OF DMX ADDRESSING

The below table shows an example of starting addresses for four fixtures assuming a first fixture with starting address of 001.

The actual starting addresses will be determined by the operator as needed to match external controller settings.

DMX ALLOCATION	1st Fixture	2nd Fixture	3rd Fixture	4th Fixture
20 channels	001	021	041	061